

ADVANCED ULTRASONIC SYSTEMS FOR A CLEANER FUTURE



TT-100N ADVANCED

Speed



Energy Savings

Robustness and Reliability

With TierraTech guarantee



Silence

60 db maximum

Ergonomics

Simplicity and comfort



Water savings

Complete watertightness that prevents loss of water by evaporation

TT-100N ADVANCED

GENERATORS AND EMITTERS

1 Ultrasonic generator with an output power of 1000W (2000Wp-p) with automatic power monitoring and frequency wave.

The operating frequency is 40 kHz with a sweeping system of $\pm 2\%$

1 ultrasonic emitter with a power of 1000W (2000Wp-p) made of AISI 316L stainless steel with a thickness of 2.5 mm, with 20 piezoelectric PZT (lead zirconate titanate) transducers with a high-performance aluminium alloy body.

TECHNICAL DATA AND MEASURES

Ultrasonic cleaning tank made of AISI 304L stainless steel with a thickness of 2 mm. Thermal-acoustic insulation of 20 mm thickness.

Tank capacity: 115 L
WFS capacity: 19 L

AISI 304L opening/closing lid with 10 mm thick thermal-acoustic insulation.

Pneumatic platform made of AISI 304L stainless steel, with a load capacity of up to 60 kg.

WFS (Waterflow system for oil separation) independent tank from the cleaning tank for the collection of oils and particles on the surface, which also includes a drainage system for the oil discharge.

Electric resistance with a power of 2250W made of AISI 316L, a metal alloy resistant to high temperatures and corrosion.

*(Optional) TTF1 bag filter for removing sludge from the bottom of the tank. Made of AISI 304L stainless steel, with a pressure gauge and the capacity to integrate bags from 5 to 200 μm .

CONTROL PANEL

7" Screen & TFT Display

Control of the preheating time for the equipment, weekly calendar, alarms, heating element, as well as full control of the lifting platform and water level. It includes the ability to create different work programs.

✉ tierratech@tierratech.com

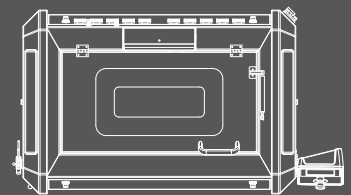
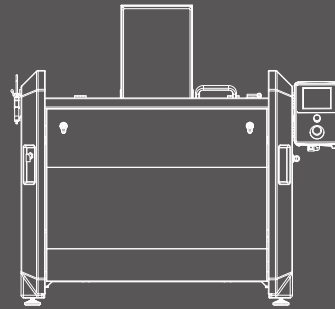

CAPACITY 115 LITRES

INTERNAL DIMENSIONS
650x390x490 mm

PLATFORM DIMENSIONS
620x325x280 mm

EXTERNAL DIMENSIONS
1420x810x900 mm

